

Dimension

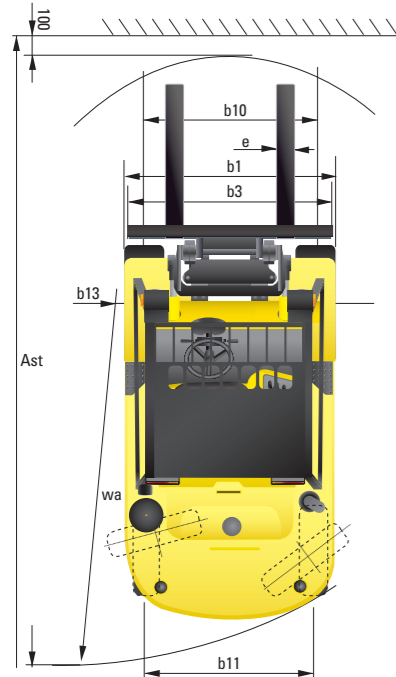

Specification

Identification					
1.1	Manufacturer	Hyundai	Hyundai	Hyundai	Hyundai
1.2	Manufacturer's type designation	35D-7E	40D-7E	45D-7E	50D-7AE
1.3	Drive: electric (battery or mains), diesel, petrol, fuel gas, manual	DIESEL	DIESEL	DIESEL	DIESEL
1.4	Type of operation: hand, pedestrian, standing, seated, order-picker	seated	seated	seated	seated
1.5	Load capacity / rated load	kg 3,500	4,000	4,500	5,000
1.6	Load center distance	c(mm) 600	600	600	600
1.8	Load distance, center of drive axle to fork	x(mm) 561	561	561	576
1.9	Wheel base	y(mm) 2,000	2,000	2,000	2,000
Weights					
2.1	Service weight	kg 5,832	6,392	6,807	7,302
2.2	Axle loading, loaded front/rear	kg 8,246 / 1,086	9,159 / 1,232	9,947 / 1,360	10,828 / 1,474
2.3	Axle loading, unloaded front/rear	kg 2,716 / 3,116	2,839 / 3,552	2,837 / 3,970	2,888 / 4,414
Wheels, Chassis					
3.1	Tires: solid rubber, superelastic, pneumatic, polyurethane	pneumatic	pneumatic	pneumatic	pneumatic
3.2	Tires size, front(Φx width)	8.25-15-14	7.50-16-12	7.50-16-12	7.50-16-12
3.3	Tires size, rear(Φx width)	7.00-12-12	7.00-12-12	7.00-12-12	7.00-12-14
3.5	Wheels, number front x rear (x-driven wheels)	2 x 2	4 x 2	4 x 2	4 x 2
3.6	Track width, front	b10 (mm) 1,132	1,282	1,282	1,282
3.7	Track width, rear	b11 (mm) 1,140	1,140	1,140	1,140
Basic Dimensions					
4.1	Mast / fork carriage tilt forward / backward (α/β)	degrees 8 / 10	8 / 10	8 / 10	8 / 10
4.2	Lowered mast height	h1 (mm) 2,235	2,200	2,200	2,200
4.3	Free lift	h2 (mm) 120	120	120	120
4.4	Lift height	h3 (mm) 3,000	3,000	3,000	2,900
4.5	Extended mast height	h4 (mm) 4,236	4,236	4,246	4,246
4.7	Overhead guard height (low opt/ std/ high opt)	h5 (mm) 2,200 / 2,240 / 2,340	2,200 / 2,240 / 2,340	2,200 / 2,240 / 2,340	2,200 / 2,240 / 2,340
4.8	Seat height / standing height	h7 (mm) 1,100	1,100	1,100	1,100
4.12	Coupling height	h10 (mm) 364	364	364	364
4.19	Overall length	l1 (mm) 4,210	4,265	4,465	4,515
4.20	Length to face of forks	l2 (mm) 3,140	3,195	3,245	3,315
4.21	Overall width	b1 (mm) 1,370	1,740	1,740	1,740
4.22	Fork dimensions(hook type)	s / e / l (mm) 50 x 122 x 1,070	50 x 150 x 1,070	50 x 150 x 1,220	60 x 150 x 1,200
4.23	Fork carriage ISO 2328, class / type A,B	III / A	III / A	IV / A	IV / A
4.24	Fork-carriage width	b3 (mm) 1,372	1,672	1,672	1,672
4.31	Ground clearance, loaded, under mast	m1 (mm) 170	155	155	155
4.32	Ground clearance, centre of wheelbase	m2 (mm) 215	200	200	200
4.33	Aisle width for pallets 1,000x1,200 crossways (LxW)	Ast (mm) 4,601	4,661	4,714	4,781
4.34	Aisle width for pallets 800x1,200 lengthways (WxL)	Ast (mm) 4,801	4,861	4,914	4,981
4.35	Turning radius	Wa (mm) 2,840	2,900	2,950	3,020
4.36	Smallest pivot point distance	b13 (mm) 999	999	999	999
Performance Data					
5.1	Travel speed, unloaded	km/h 27.7	26.7	26.7	26.6
5.2	Lift speed, loaded / unloaded	mm/s 550 / 570	540 / 570	530 / 570	460 / 490
5.3	Lowering speed, loaded / unloaded	mm/s 500 / 500	500 / 500	500 / 500	500 / 500
5.5	Drawbar pull, loaded	kg 4,015	4,035	4,042	4,050
5.7	Gradient performance, loaded	% 42.0	37.3	33.9	31.0
5.9	Acceleration time, loaded / unloaded(10m)	-	-	-	-
5.10	Service brake	hydraulic	hydraulic	hydraulic	hydraulic
Engine					
6.1	Engine manufacturer / type	HMC D4DD	HMC D4DD	HMC D4DD	HMC D4DD
6.2	Engine power acc. to ISO 1585	kw 70	70	70	70
6.3	Rated speed	1/min 2,300	2,300	2,300	2,300
6.4	No. of cylinder / cubic capacity	cm ³ 3,907	3,907	3,907	3,907
6.5	Fuel consumption acc. To VDI cycle	l/h 3.2	3.4	3.63	3.83
Other Details					
8.1	Type of drive control	Torque Converter 2/2	Torque Converter 2/2	Torque Converter 2/2	Torque Converter 2/2
8.2	Operating pressure (system / attach)	bar 210	210	210	210
8.3	Oil volume (hydraulic)	l 66	66	66	66
8.4	Noise (at driver's ear according to DIN 12053)	db(A) 82	82	82	82

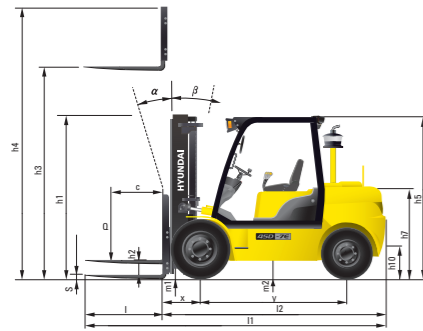

Some of the photos may include optional equipment.

We build a better future

HYUNDAI DIESEL FORKLIFT TRUCKS Applied Tier 3 Engine

35D/40D/45D-7E 50D-7AE

HYUNDAI FORKLIFT
HEAVY INDUSTRIES CO.,LTD.

Head Office (Sales Office)
14TH FL., HYUNDAI BLDG. 140-2, KYE-DONG, JONGNO-GU, SEOUL, KOREA 110-793
TEL (82) (2) 746-4526, 4529 FAX (82) (2) 746-7444-7445

Americas Operation : Hyundai Construction Equipment Americas, Inc.
955 ESTES AVENUE, ELK GROVE VILLAGE, IL. 60007, U.S.A. TEL (1) 847-437-3333 FAX (1) 847-437-3574

Europe Operation : Hyundai Heavy Industries Europe N.V.
VOSSENDAAL 11, 2440 GEEL, BELGIUM TEL (32) 14-56-2200 FAX (32) 14-59-3405

PLEASE CONTACT

www.hyundai-ce.com

2011. 10. Rev 2

HYUNDAI
HEAVY INDUSTRIES CO.,LTD.

35/40/45D -7E

50D -7AE

New criteria of forklift trucks

Hyundai introduces a new line of 7E series diesel forklift trucks. Excellent power and performance make your business more profitable.



■ Some of the photos may include optional equipment.

The new master on the job-site!

Smooth running, efficient and ergonomically designed, 35/40/45D-7E, 50D-7AE series are made to meet your needs.



HMC D4DD

High power engine - HMC D4DD

Market approved quality of HMC D4DD engine ensures incomparable performance, durability and excellent fuel efficiency. This engine meets EPA Tier-III and EU stage IIIA emission regulations.

70kW/2,300rpm
35kgf-m/1,600rpm



Fast and stable performance

Being able to quickly raise and lower the mast, as well as tilt it forward and backward, providing the best operational conditions during unloading. When the truck is fully loaded, mast lowering speed is carefully controlled to ensure safety by the down control valve.

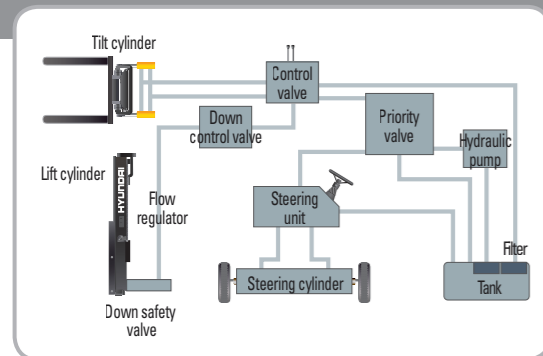

State-of-the-art hydraulic system

The latest large-capacity hydraulic system reacts quickly during operation, and a low-noise control valve increases both efficiency and durability.



OPSS (Operator Presence Sensing System)

Control of mast tilting, lifting and lowering is not possible through operation of the appropriate control when the operator is not in the seated position. (Option)



Fully hydrostatic power steering

A hydraulic steering system always guarantees smooth and flexible steering, preventing overrun and kick-back.



Increased mast tilting angle

The mast tilting angle of 8 degrees forward and 10 degrees backward, the operator can safely and rapidly perform loading and unloading jobs.



■ Some of the photos may include optional equipment.

Faster travel speed & gradeability

The powerful high-output engine provides greater acceleration, better gradeability and faster travel speed on any tough terrain or slope.



Travel speed(Unloaded)

35D-7E : 27.7km/h 45D-7E : 26.7km/h
40D-7E : 26.7km/h 50D-7AE : 26.6km/h

Gradeability(Loaded)

35D-7E : 42.0%
40D-7E : 37.3%
45D-7E : 33.9%
50D-7AE : 31.0%

Ergonomic operator friendly compartment design!

A design based on human engineering relieves fatigue and increases operator's efficiency.

Operator friendly gauges and water-resistant monitor panel



- | | |
|---------------------------------------------|----------------------------|
| 1 Parking brake lamp | 9 Water separator lamp |
| 2 Directional indicators | 10 Pre-heater indicator |
| 3 Fuel warning lamp | 11 Water temperature gauge |
| 4 Engine oil warning lamp | 12 Fuel gauge |
| 5 Transmission oil temperature warning lamp | 13 Hour meter |
| 6 Battery charging warning lamp | 14 Engine check lamp |
| 7 Air cleaner filter warning light | 15 Seat belt warning |
| 8 Working light indicator | 16 OPS warning |



Easily adjustable suspension seat

An attractive and adjustable seat, based on a human engineering design, provides great comfort, safety and durability.

New high visibility for safe operation

The operator is able to work with increased safety and accuracy due to a wider view mast.



■ Some of the photos may include optional equipment.



Ergonomically positioned pedals

Based on human engineering, the accelerator, brake and inching pedals are optimally positioned for convenience while operating the equipment.



Cup holder & console box

Additional storage spaces are located inside the operating space for operator's convenience.



Quick response of operating control levers

Only minimal operator's effort is required for precise, safe and productive control.



Adjustable steering wheel

Steering wheel with horn button can be adjusted by a lever on the right-hand side for the most comfortable operator position.



Easy and safe shift lever

A single lever on the left side of the steering column gives the operator fast, easy control of direction. The lever must be in the neutral position before the engine can be started.



Secondary Horn

Secondary Horn gives access to lights and horn.

Danger-free through high durability!

Safety and durability are priorities in the design of the equipment.



Strong overhead guard

The safety overhead guard exceeds EEC and ANSI regulations and protects the operator during hazardous jobs.



Parking brake

Ratchet type parking brake requires less efforts from the operator to set.

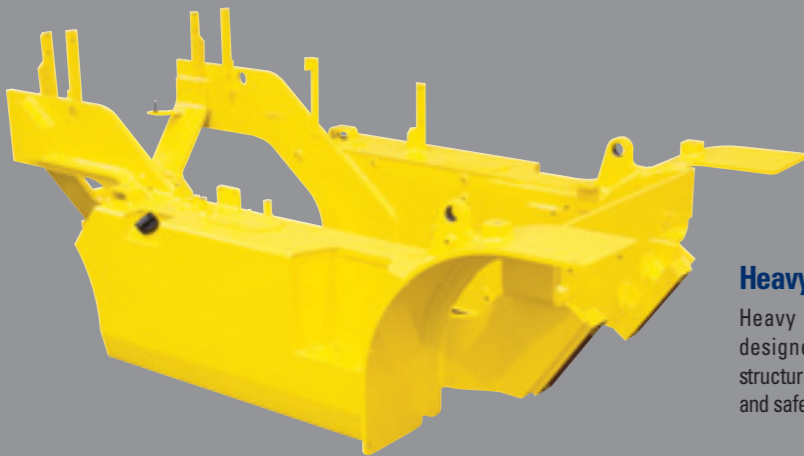

Heavy duty single unit frame

Heavy duty single unit type frame, designed on the basis of accurate structural analysis, guarantees durability and safety.



■ Some of the photos may include optional equipment.



Highly durable transmission and drive axle

Powershift transmission provides fast travel speed and quiet travel under any heavy load condition, and boosts work efficiency.



Fuel tank safety valve

Integrated safety check valve shuts off fuel supply in the unlikely condition of a truck overturn.



Expansion bellows

The expansion bellows absorbs vibration and reduces noise generated from the exhaust gas system and also extends the life cycle of exhaust gas system.



Large footboard & hand grip

Wide "open" step offers convenience and safety when entering and exiting truck.



Bright, protected headlights

Bright, protected headlights are positioned for exceptional visibility.

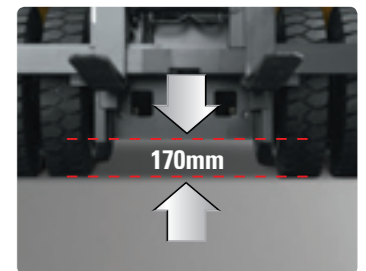

Ground clearance

The engine and transmission are assembled horizontally and positioned high in the frame to protect major components during operation on rugged surface.

Centralized design for easy service!

An ideal arrangement of component parts ensures easy accesses and conveniences for the maintenance.



Easy change air cleaner

The air filter is readily accessible for cleaning or replacement. (7inch Cyclone Type)



■ Some of the photos may include optional equipment.



Visible precleaner

Efficient, accessible pre-cleaner provides for longer engine life



Double battery installation



Easy-to-change radiator



Quick and easy engine oil check



Electrically monitored air filter

Air cleaner sensor alerts the operator of a restricted air filter and allows replacement before damage.



Easy maintenance oil check

The T/M oil level can be checked easily without any disassembly.



Brake fluid reservoir

Highly visible, easily accessible reservoir makes for quicker daily inspections.



An accessible, compact fuse box for easy inspection

