

Dimensions

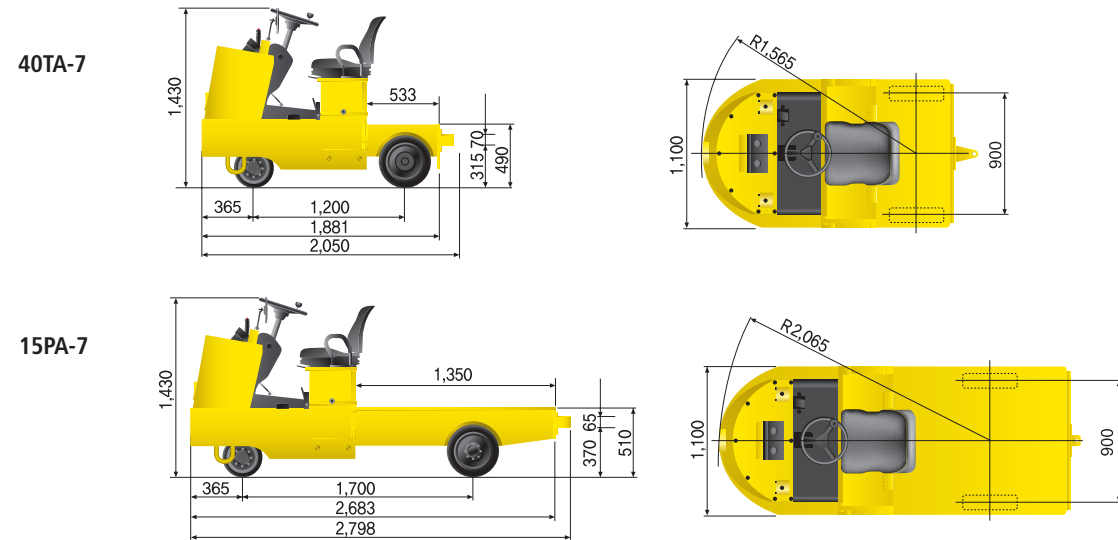

Specifications

Description		Unit	40TA-7	15PA-7	
Performance	Capacity	kg (lb)	4,000 (8,820)	1,500 (3,310)	
	Travel Speed	Loaded	km/h (mph)	8 (5)	
		Unloaded	km/h (mph)	10 (6)	
	Outside Turning Radius	mm (in)	1,565 (61.6)	2,065 (81.3)	
Dimension	Overall Length	mm (in)	2,050 (80.7)	2,798 (110.2)	
	Overall Width	mm (in)	1,100 (43.3)	1,100 (43.3)	
	Overall Height	mm (in)	1,430 (56.3)	1,430 (56.3)	
	Wheel Base	mm (in)	1,200 (47.2)	1,700 (66.9)	
	Wheel Tread - Rear	mm (in)	900 (35.4)	900 (35.4)	
	Weight (Without Battery)	kg (lb)	748 (1,650)	755 (1,660)	
Power Train	Drive Motor	kW	5.0	5.0	
	Battery	Voltage	V	48	48
		Capacity	AH/5HR	280	280
		Min. Weight	kg (lb)	400 (880)	400 (880)
	Max. Weight	kg (lb)	720 (1,590)	720 (1,590)	
Control Type		-	AC	AC	
Tire	Size, Front	-	305X127(1)	305X127(1)	
	Size, Rear	-	4.00-8(2)	5.00-8-8PR(2)	

* Beacon lamp, Front Urethane tire, Non-Marking Tire, Cargodeck, Suspension Seat, Head guard are Optional.

* Standard and optional equipment may vary. Contact your Hyundai dealer for more information. The machine may vary according to International standards.

* The photos may include attachments and optional equipment that are not available in your area.

* Materials and specifications are subject to change without advance notice.

* All imperial measurements rounded off to the nearest pound or inch.

PLEASE CONTACT

HYUNDAI
HEAVY INDUSTRIES CO.,LTD.
CONSTRUCTION EQUIPMENT

Head Office (Sales Office)
1 JEONHA-DONG, DONG-GU, ULSAN, KOREA TEL: (82) 52-202-7970, 7729, 0971 FAX: (82) 52-202-7979, 7720

U.S. Operation: Hyundai Construction Equipment Americas, Inc.
955 ESTES AVENUE, ELK GROVE VILLAGE, IL. 60007, U.S.A. TEL: (1) 847-437-3333 FAX: (1) 847-437-3574

European Operation: Hyundai Heavy Industries Europe N.V.
VOSSENDAAL 11, 2440 GEEL, BELGIUM TEL: (32) 14-56-2200 FAX: (32) 14-59-3405

India Operation: Hyundai Construction Equipment India Pvt., Ltd.
PLOT NO.A-2, CHAKAN INDUSTRIAL AREA, VILL.- KHALUMBRE, TALUK.- KHED., DIST.- PUNE 410 501, INDIA
TEL: (91) 21-3530-1700 FAX: (91) 21-3530-1712

www.hyundai-ce.com

2010.04 Rev. 0



*Photo may include optional equipment.

HYUNDAI ELECTRIC TOWING / PLATFORM TRUCKS Environmentally - Friendly

40TA/15PA-7

HYUNDAI
HEAVY INDUSTRIES CO.,LTD.

We build a better future

Revolutionizing the productivity in the material industry!

Maximize the productivity of your business with our powerful and agile electric trucks.

With our vast experience in the production of construction equipment, Hyundai is able to meet the demands of our consumers. 40TA-7/15PA-7, produced by Hyundai are not only economical, environmentally friendly and allow for convenient maintenance, but their improved maneuverability and quiet operation make our products the most widely-used towing maintenance truck in trade and distribution companies around the world.



*Photo may include optional equipment.

Quiet and Environmentally-Friendly 40TA-7/15PA-7

Hyundai's towing / platform trucks are electrically powered to provide quiet and environmentally-friendly operation for use not only in factories, but in places of business such as food plants, where hygiene and sanitation are a must.



Comfortable Operator's Space

As adopting EPS(Electrical Power Steering) system, you feel smooth steering and ergonomical location of controller minimizes operator's fatigue. And it provides safety operation with wide front and rear view.

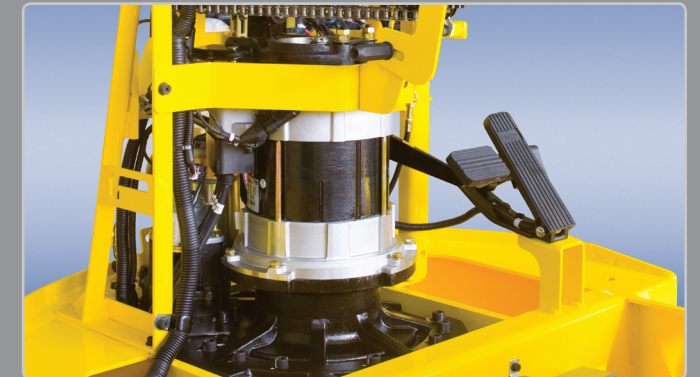

Profitable AC-motor Adoption

Applying AC-motor improves output power and precision of speed control. It also reduces maintenance cost and fault.



Centralized Panel and Switch

It is easy to maintain the equipment by adopting centralized panel that indicates the equipment's status with self-diagnosis function.



Adjustable Steering Wheel

The steering wheel can be adjusted by a lever on the left-hand side for the most comfortable operating position.



Convenient Battery Change

It ensures additional space between battery and main frame for smooth movement of the battery.



Storage Console

A storage console is installed for the operator's benefit.



Accelerator & Brake Pedal

Based on human engineering the accelerator, brake and inching pedals are optimally positioned for convenience while operating the equipment.



Improved Maintenance Ability

Integrated electrical devices enhanced maintenance ability and durability.



Parking Brake System

Ratchet type parking brake requires less effort from the operator to set.